



moview
UPHOLDING A VISION.

tvmount

Product Number WLF

largeflush

Supports Flat Panels up to 60" or 200 lbs.



Product features:

- 360° rotation portrait to landscape – allows for easy leveling.
- Screws can be loosened on wall hooks to allow for easy horizontal position adjustment of up to 7 inches.
- Screws can be loosened on pivot plate for a vertical adjustment of up to 5-1/2 inches.
- Innovative design allows for hassle-free installation of flat panel
- Upright mounting hooks allow for easy installation.
- Variety of fasteners and spacers included to accommodate most flat panel VESA patterns.

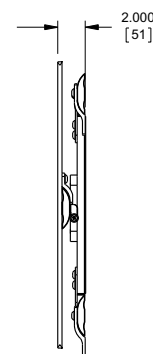
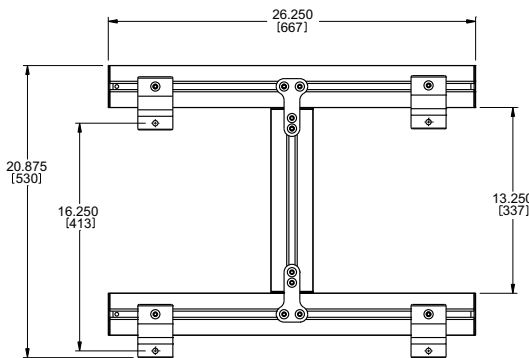
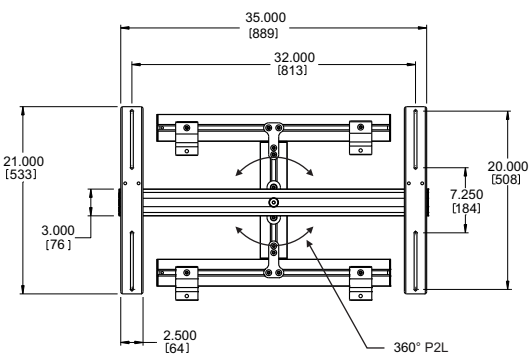

Product specifications:

Model: WLF

	ENGLISH	(METRIC)
SUPPORTED SCREEN SIZE:	37"-60"	(94cm - 152.4cm)
MAX LOAD:	200lbs	(90.7kg)
HOLE PATTERN RANGE: (VESA)	7-7/8 X 7-7/8", 7-7/8 X 15-3/4", 15-3/4 X 15-3/4", 15-3/4 X 23-5/8", 19-5/8 X 23-5/8", 19-5/8 X 31-1/2"	(200 X 200mm, 200 X 400mm 400 X 400mm, 400 X 600mm 500 X 600mm, 500 X 800mm)
DIMENSIONS:	21" W X 35" H X 2" D	(54 W X 89 H X 5 D cm)
SHIPPING WEIGHT:	17lbs	(7.7kg)

**10 Year Warranty - Minimal Assembly Required
Designed, Engineered, and Manufactured in USA**



leveling

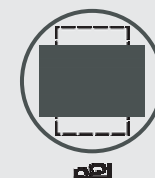

P2L