



UPHOLDING A VISION.

tvmount

Product Number W60MC

mobilecart

Supports Flat Panels 37" to 60" or 125 lbs.



5" CASTERS



FLEXI GROMMETS



LARGE, STABLE BASE



VERSATILE TILT BRACKET

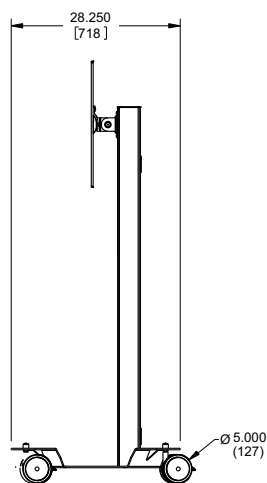
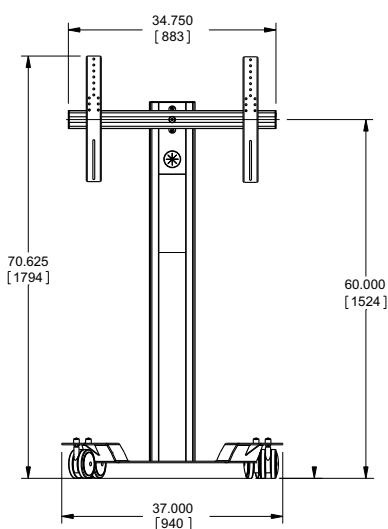

Product features:

- Mobility with oversized casters for easy travel over institutional thresholds, uneven flooring and more
- Sturdy, multi-position flat panel mounting bracket with tilt, self-leveling and portrait-to-landscape feature
- Integrated wire management channel with removable panels for access
- Large, flat base which can be utilized for holding speakers, amplification, or workstation
- Options include: locking storage, power suppression and distribution, shelving choices, integrated keyboard and mouse tray, workstation holders

Product specifications:

Model: W60MC

	ENGLISH	(METRIC)
SUPPORTED SCREEN SIZE:	37"-60"	(94.0cm - 152.4cm)
MAX LOAD:	125lbs	(56.7kg)
HOLE PATTERN RANGE: (VESA)	7-7/8" X 7-7/8", 7-7/8" X 15-3/4", 15-3/4" X 15-3/4", 15-3/4" X 23-5/8", 19-5/8" X 23-5/8", 19-5/8" X 31-1/2"	(200 X 200mm, 200 X 400mm, 400 X 400mm, 400 X 600mm, 500 X 600mm, 500 X 800mm)
DIMENSIONS:	37" W X 70-5/8" H X 28-1/4" D	(94.0 W X 1794.0 H X 718.0 D cm)
SHIPPING WEIGHT:	84.5lbs	(38.3kg)

**10 Year Warranty - Minimal Assembly Required
Designed, Engineered, and Manufactured in USA**



tilt



mobile



leveling

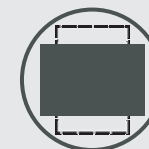

VESA