

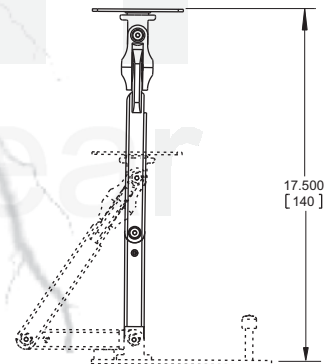

Product features:

- Epoxy based coating with superior corrosion and UV resistance.
- Passed NEMA testing for ASTM D4329 UV Stable Certification and ASTM B117 Salt Fog Certification (400 Hrs Accelerated).
- Bumper and Stop design for mobile applications.
- Innovative spring lock design holds panel firmly in folded position.
- Bumper and Stop design for mobile applications.
- Rigid, solid aluminum construction for minimal deflection at maximum loads, with all stainless steel fasteners.
- Display tilt in extended position.
- No buttons, screws, or knobs required. Simply adjust your display to the desired position and walk away.

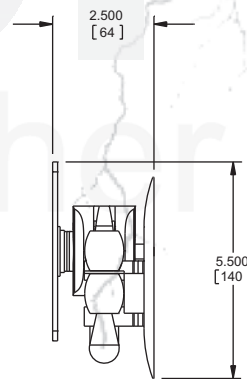
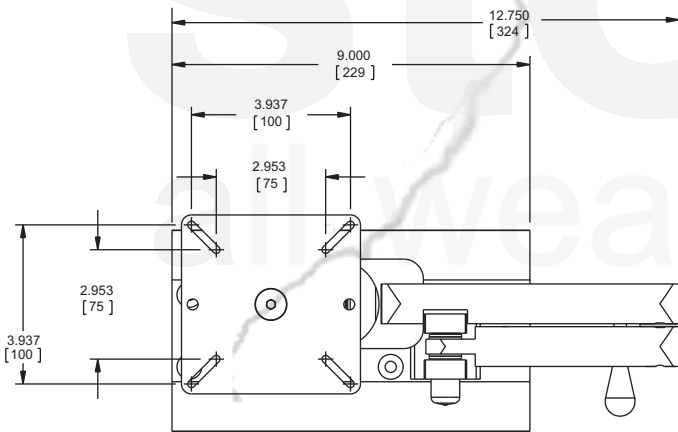

Product specifications:

Model: MSDSL-1W

Limited Lifetime Warranty - Minimal Assembly Required
Designed, Engineered, and Manufactured in USA

	ENGLISH	(METRIC)
COMMON SCREEN SIZES:	10"-23"	(25.4cm - 58.4cm)
MAX LOAD:	15 lbs	(6.8 kg)
HOLE PATTERN RANGE: (VESA)	3 X 3", 4 X 4"	(75 X 75mm, 100 X 100mm)
DIMENSIONS:	12-3/4" W X 5-1/2" H X 2-1/2" D	32.4 W X 14.0 H X 6.3 D cm
SHIPPING WEIGHT:	5.8 lbs	2.6 kg



tilt



leveling



panel



panel